

The 3 Pass Wet Back Boiler

Available in Steam or Hot Water Versions
 Ranging from 30 to 1800HP, 15 to 300# Steam,
 30 to 160# hot water.

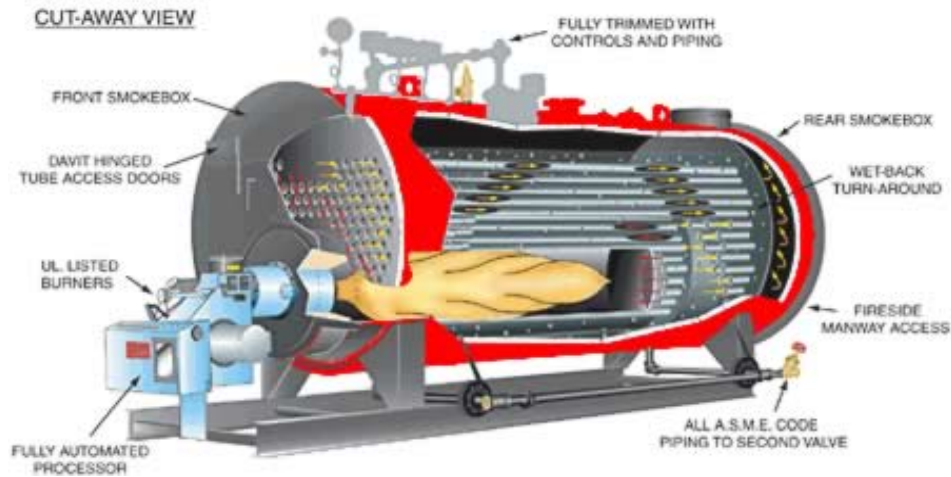

WET BACK ADVANTAGE

Dry backs are subject to deteriorating rear refractory, leaking baffles, leaking door seals, and often found with a heat-stressed rear tubesheet. Fragile refractory baffling and door seals will require continuous monitoring, maintenance, and replacement, costing thousands of dollars in materials and specialized labor cost over the life of the boiler. In addition, broken baffles and leaking seals will short-circuit boiler efficiency up until repairs can be made, and downtime during repairs can bring your production process to a halt.

WET-BACK DESIGN

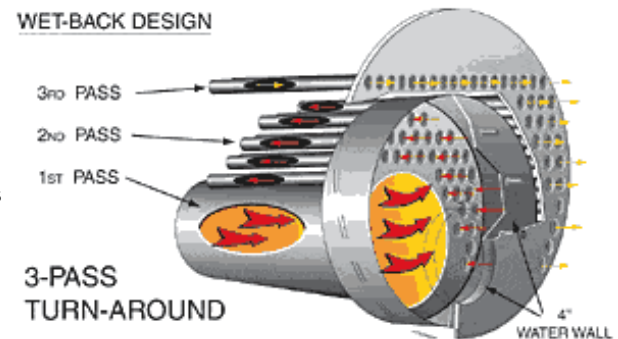

All of those frustrating problems have been designed out of the CRG 3 pass Wet back. It has a full wet back radiant heat transfer area that promotes superior internal water circulation and rapid heat absorption. Separate rear tubesheets allow each pass of tubes to expand and contract at its own rate without tube-to-sheet stress. Tubes are mechanically rolled, flared and beaded, making any tube service a simple matter. The only rear refractory is a 18 inch plug which allows access to the furnace for inspection.

STANDARD FEATURES :

Durability

Built in accordance with the ASME Code, the wet back design has proven to give much longer useful life cycles than dry back boilers.

Quality

Each unit is tested and inspected by Hartford and is registered with the National Board of Boiler and Pressure Vessel Inspectors.

Design

CRG Boiler utilizes state of the art computer design techniques in every boiler. This accounts for accurate calculations of construction materials and optimum utilization of the boiler's performance criteria.

Efficiency

The 3 pass wet back is designed for optimum fuel efficiency and has proven in certified tests to meet and often exceed the efficiencies of 4-pass boilers.

Low Maintenance

There is no refractory rear door, to maintain and no refractory baffles to replace. Elimination of these components results in thousands of dollars of savings.

Tube Sheets

The wet back has independent tube sheets with uniform temperatures. Three and four pass dry back boilers have tube sheets with large temperature variations and this results in premature tube failure and cracks in the tube sheets.

Easy Access

Since there is no large refractory rear door, one man can easily remove the rear cover plates for access to the tubes. Front doors can be opened without removing burner components or controls.

Compact

With computer aided design, CRG has made the wet back a space saving workhorse without sacrificing the principle of 5 sq. ft. of heating surface per BHP.

Combustion

CRG uses name brand burner components with proven reliability. Every unit is boiler/burner compatible and tested at the factory prior to shipment.

Standard Steam Trim

- Operating & limit pressure control
- Modulating pressure control (when appl)
- Water column with gauge glass combination low water cut-off & pump control
- Probe type auxiliary low water cut-off with manual reset
- Water column drain valve
- Safety relief valve(s)) per ASME Code
- Steam Gauge
- Stack Thermometer

Standard Water Trim

- Operating & limit temperature control
- Modulating temperature control (when appl)
- Low water cut-off control with manual reset
- Combination pressure, temperature gauge
- Hot water return baffle for shock resistance
- Safety relief valve(s)) per ASME Code
- Stack thermometer

BOILER HORSEPOWER			30	40	50	60	70	80	100	125	
HEATING SURFACE	FIRESIDE	SQ. FT.	150	200	250	300	350	400	500	625	
STEAM OUTPUT	FROM & @212 F	LB/HR	1035	1380	1725	2070	2415	2760	3450	4313	
GROSS OUTPUT		MBH	1004	1339	1674	2009	2343	2678	3348	4184	
FIRING RATE, GAS	1,000 BTU/CF	CFH	1260	1680	2100	2520	2940	3360	4200	5250	
FIRING RATE, LP GAS	91,500 BTU	GPH	13.8	18.4	23	27.5	32	36.7	46	57	
FIRING RATE, #2 OIL	140,000 BTU	GPH	9	12	15	18	21	24	29.9	37.4	
FIRING RATE, #5 & #6 OIL	150,000 BTU	GPH	8.4	11.2	14	16.8	19.6	22.4	28	35	
*NOTE: 1 STEAM OUTLET SIZE	150 PSI	IN	1 1/2	2	2 1/2	2 1/2	3	3	4	4	A
*NOTE: 2 STEAM OUTLET SIZE	15 PSI	IN	4	4	4	6	6	6	8	8	A
*NOTE: 2 SUPPLY SIZE	30 PSI	IN	4	4	4	6	6	6	8	8	B
*NOTE: 2 RETURN SIZE	30 PSI	IN	4	4	4	4	4	4	6	6	C
FEEDWATER CONNECTION		IN	3/4	3/4	3/4	1	1	1 1/4	1 1/4	1 1/4	D
BOTTOM BLOWDOWN SIZE	HIGH PRESS.	IN	1	1 1/4	1 1/4	1 1/4	1 1/4	1 1/4	1 1/4	1 1/4	E
BOTTOM BLOWDOWN SIZE	LOW PRESS. & HW	IN	1 1/4	1 1/4	1 1/4	1 1/2	1 1/2	1 1/2	1 1/2	1 1/2	E
STACK OUTLET SIZE O.D.		IN	10	10	10	12	12	12	14	14	F
FURNACE O.D.		IN	14	14	16	18	18	18	22	26	G
SHELL I.D.		IN	40	40	44	48	48	48	54	60	H
SUPPLY HEIGHT		IN	55 1/4	55 3/8	59 3/4	63 5/8	66 5/8	66 5/8	74 3/4	81 3/4	I
WIDTH WITHOUT TRIM		IN	45 1/4	45 1/4	50	53 5/8	53 5/8	53 5/8	60	66 1/2	J
WIDTH WITH TRIM		IN	58	58	60	66	66	66	72	79	K
SKID WIDTH		IN	34	34	36	40	40	40	44	48	L
END OF SKID TO FRONT PLATE		IN	13 1/2	14 1/4	15 1/4	15 1/4	15 1/4	15 1/4	21 3/4	25 1/8	M
VESSEL SHELL TO FLOOR		IN	12	12	12	12	12	12	14	15	N
SKID LENGTH		IN	81	99	102	102	102	114	114	132	O
STACK OUTLET HEIGHT		IN	58 5/8	58 5/8	62 5/8	66 5/8	66 5/8	66 5/8	74 3/4	81 3/4	P
BLOWDOWN LOCATIONS		IN	35 3/4	41	31 3/4	29 3/4	29 3/4	29 3/4	29 3/4-66	32 7/8-78	Q
STEAM OUT LOCATION	15 PSI & UP	IN	38 3/4	41 3/4	40 1/4	49 3/4	49 3/4	58 3/4	55 3/4	55 7/8	R
SUPPLY LOCATION		IN	20 1/4	20 3/4	33	37 3/4	37 3/4	43 3/4	32 3/4	32	S
RETURN LOCATION		IN	59 1/4	74 3/4	78	85 3/4	85 3/4	97 3/4	90 3/4	102	T
BURNER PROJECTION	FROM FRONT PLATE	IN	31 5/8	31 5/8	31 3/8	31 3/8	31 3/8	31 3/8	31 3/8	34 3/4	U
TUBE REMOVABLE	FRONT	IN	68	85	88	91	91	102	96	108	V
STACK OUTLET LOCATION		IN	78 1/2	95 3/4	98 3/4	104 3/4	104 3/4	116 3/4	111 3/4	123 7/8	W
APPROX. OVERALL LENGTH	STD. BURNER	IN	117	134	137	144	144	160	152	167	X
1 1/4" SURFACE BLOW-OFF CONNECTION		IN	29 3/4	29 3/4	31 1/4	40 3/4	40 3/4	46 3/4	45 3/4	41 7/8	Y
APPROX. SHIPPING WEIGHT	150 PSI	LBS.	3500	4100	4500	5965	6200	6900	9500	10400	
APPROX. SHIPPING WEIGHT	15 & 30 PSI	LBS.	3400	4000	4500	5665	5900	6200	7200	9400	
WATER CAPACITY @ NWL		GAL.	213	300	315	400	381	436	484	676	

WATER CAPACITY FLOODED		GAL.	250	323	385	453	455	499	578	788	
BOILER HORSEPOWER			30	40	50	60	70	80	100	125	

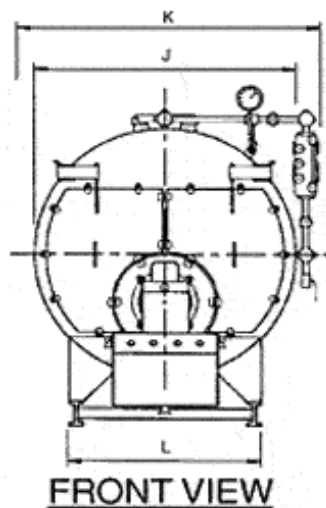
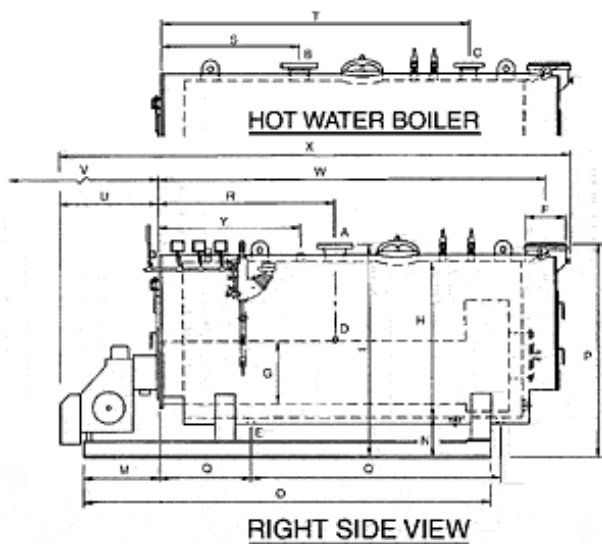

BOILER HORSEPOWER			150	200	250	300	350	400	500	600	700	750	800	900	1000	1200	1500	
HEATING SURFACE	FIRESIDE	SQ. FT.	750	1000	1250	1500	1750	2000	2500	3000	3500	3750	4000	4500	5000	6000	7500	
STEAM OUTPUT	FROM & @212 F	LB/HR	5175	6900	8625	10350	12075	13800	17250	20700	24150	25875	27600	31050	34500	41400	51750	
GROSS OUTPUT		MBH	5021	6695	8369	10043	11716	13390	16738	20085	23432	25106	26780	30128	33475	40170	50213	
FIRING RATE, GAS	1,000 BTU/CF	CFH	6300	8400	10500	12600	14700	16800	21000	25200	29400	31500	33600	37800	42000	50400	63000	
FIRING RATE, LP GAS	91,500 BTU	GPH	69	92	115	138	160	184	230	275	320	344	368	413	460	550	688	
FIRING RATE, #2 OIL	140,000 BTU	GPH	45	60	75	90	105	120	150	180	210	225	240	270	300	360	450	
FIRING RATE, #5 & #6 OIL	150,000 BTU	GPH	42	56	70	84	98	112	140	168	196	210	224	252	280	336	420	
A *NOTE: 1 STEAM OUTLET SIZE	150 PSI	IN	4	4	6	6	6	6	6	6	8	8	8	8	8	10	10	A

3 Pass Wet Back Spec

A	*NOTE: 2 STEAM OUTLET SIZE	15 PSI	IN	8	8	10	10	10	10	10	12	12	12	12	14	14	14	14	A
B	*NOTE: 2 SUPPLY SIZE	30 PSI	IN	8	8	10	10	10	10	10	12	12	12	12	12	12	14	14	B
C	*NOTE: 2 RETURN SIZE	30 PSI	IN	6	6	8	8	8	8	8	8	10	10	10	12	12	14	14	C
D	FEEDWATER CONNECTION		IN	1 1/4	1 1/2	1 1/2	2	2	2	2	2 1/2	2 1/2	2 1/2	2 1/2	2 1/2	2 1/2	2 1/2	2 1/2	D
E	BOTTOM BLOWDOWN SIZE	HIGH PRESS.	IN	1 1/4	1 1/4	1 1/4	1 1/2	1 1/2	1 1/2	1 1/2	1 1/2	2	2	2	2	2	2	2	E
E	BOTTOM BLOWDOWN SIZE	LOW PRESS. & HW	IN	2	2	2	2	2	2	2	2	2	2	2	2	2	2	2 1/2	E
F	STACK OUTLET SIZE O.D.		IN	16	16	18	20	20	24	24	28	28	28	30	30	30	32	32	F
G	FURNACE O.D.		IN	26	30	34	34	34	38	38	44	52	52	52	52	52	56	56	G
H	SHELL I.D.		IN	60	66	84	84	84	90	96	102	112	112	112	112	112	126	136	H
I	SUPPLY HEIGHT		IN	81 3/4	90 3/4	109	109	109	115	121	127 1/4	138 1/4	138 1/4	138 1/4	138 1/4	138 1/4	152 1/4	162 1/4	I
J	WIDTH WITHOUT TRIM		IN	66 1/2	72 1/2	90 3/4	90 3/4	90 3/4	96 1/4	102 3/4	108 3/4	119	119	119	119	119	133 1/2	143 1/2	J
K	WIDTH WITH TRIM		IN	79	84	103	103	102	106	115	121	136	136	136	136	136	153	162	K
L	SKID WIDTH		IN	48	51	64	64	64	70	76	78	92	92	92	92	92	108	114	M
M	END OF SKID TO FRONT PLATE		IN	25 1/8	21 1/4	28 5/8	26 5/8	34 5/8	30 5/8	31 5/8	62 5/8	35 1/8	34 5/8	36 5/8	505/8	64 5/8	61 5/8	59 5/8	N
N	VESSEL SHELL TO FLOOR		IN	15	18	18	18	18	18	18	18	18	18	18	18	18	18	18	O
O	SKID LENGTH		IN	156	168	180	180	204	198	212	240	207	218	228	264	288	294	320	P
P	STACK OUTLET HEIGHT		IN	81 3/4	90 3/4	109	109	109	115	122	128 1/4	138 1/4	138 1/4	138 1/4	138 1/4	138 1/4	152 1/4	162 1/2	Q
Q	BLOWDOWN LOCATIONS		IN	32 7/8- 102	33 7/8- 120	35 7/8- 120	35 7/8- 120	41 7/8- 132	47 7/8- 126	47 3/8- 137	46 7/8- 146	51 3/8- 126 1/2	49 7/8- 138	49 7/8- 149	50 3/8- 169	49 7/8- 198	53 7/8- 190	57 1/8- 214	R
R	STEAM OUT LOCATION	15 PSI & UP	IN	73 7/8	80 3/4	72	71 7/8	84 7/8	93 3/8	96 7/8	96 3/8	90 3/8	90 3/8	101 3/8	122	115 7/8	122 3/8	135 7/8	S

S	SUPPLY LOCATION		IN	32	46 1/2	54 3/4	54 3/4	56 1/4	55 7/8	60 3/8	60	51 3/8	51 3/8	51 3/8	78	78	81	65 7/8	T
T	RETURN LOCATION		IN	114	130 1/2	144 3/4	144 3/4	151 1/4	147 7/8	162 3/8	160	140 3/8	140 3/8	153 3/8	180	200	206	245 7/8	U
U	BURNER PROJECTION	FROM FRONT PLATE	IN	34 3/4	34 3/4	47 1/2	47 1/2	38 1/4	52 1/4	52 1/4	52 1/4	52 3/4	52 3/4	65 7/8	65 7/8	65 7/8	63	76	V
V	TUBE REMOVABLE	FRONT	IN	132	150	150	150	168	168	184	191	173	185	195	217	239	239	264	W
W	STACK OUTLET LOCATION		IN	148 7/8	168 3/4	172 7/8	172 7/8	190 7/8	192 7/8	208 7/8	222 5/8	201 1/2	214	225 7/8	247 7/8	269 7/8	270 7/8	298 7/8	X
X	APPROX. OVERALL LENGTH	STD. BURNER	IN	193	214	223	223	241	259	275	306	271	283	309	331	353	352	393 3/8	Y
Y	1 1/4" SURFACE BLOW-OFF CONNECTION		IN	58 7/8	61 3/8	57 3/8	57 3/4	68 7/8	68 3/8	72 7/8	72 3/8	75 3/8	74 3/8	86 3/8	102	85 7/8	106 3/8	107 7/8	
	APPROX. SHIPPING WEIGHT	150 PSI	LBS.	11800	16600	27100	27100	30200	32200	37900	46400	48100	54100	57200	61300	66400	82000	103000	
	APPROX. SHIPPING WEIGHT	15 & 30 PSI	LBS.	10800	13700	25600	25800	28200	29500	34400	37400	40100	42500	44900	49700	54600	74000	93000	
	WATER CAPACITY @ NWL		GAL.	785	1126	1874	1844	2068	2440	3075	3315	3341	3566	3791	4170	4640	6055	7743	
	WATER CAPACITY FLOODED		GAL.	1027	1350	2276	2246	2518	3000	3423	4076	3983	4253	4523	4970	5525	7295	10069	
	BOILER HORSEPOWER			150	200	250	300	350	400	500	600	700	750	800	900	1000	1200	1500	

(NOTE: 1) 3" & ABOVE ARE 300# ANSI FLANGE

(NOTE: 2) 4" & ABOVE ARE 150# ANSI FLANGE

70 HP & LARGER 12" X 16" MANWAY

DIMENSIONS SUBJECT TO CHANGE WITHOUT NOTICE.

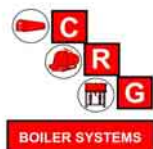

C.R.G. Electric, Inc /CRG Boiler Systems
 PO Box 69008 Odessa, Tx 79769
 Ph. (432) 381-2493 Fax. (432) 381-2724
www.crgboilers.com